











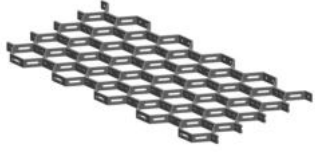





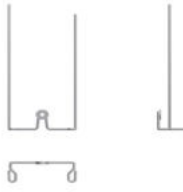

AS Schöler GmbH

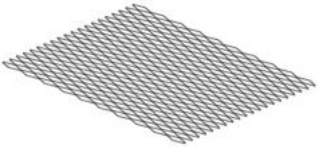
Übersicht Produktgruppe 08

 <p>Ankerkloben</p>	 <p>Flexmesh</p>	 <p>Hexmesh</p>
 <p>Halteklammer</p>	 <p>Lochblech</p>	 <p>LTB</p>
 <p>Maueranker</p>	 <p>MPU-A</p>	 <p>MPU-B</p>
 <p>MPU-C</p>	 <p>STA</p>	 <p>Stahlnadeln</p>
 <p>Streckmetall</p>	 <p>Konsole</p>	 <p>Konsole</p>
 <p>Konsole</p>	 <p>Konsole</p>	 <p>Konsole</p>
 <p>Konsole</p>		

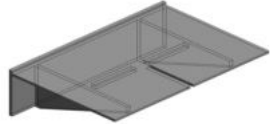
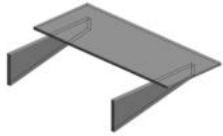

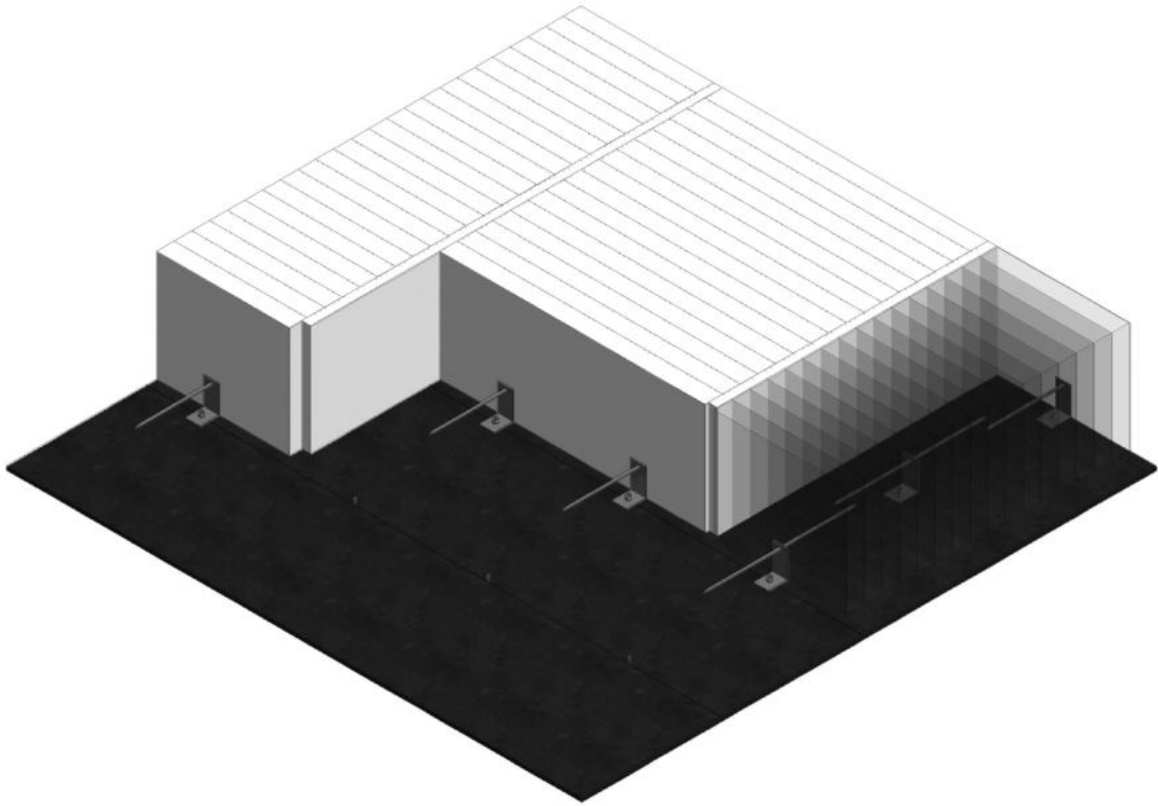
Einbaubeispiel

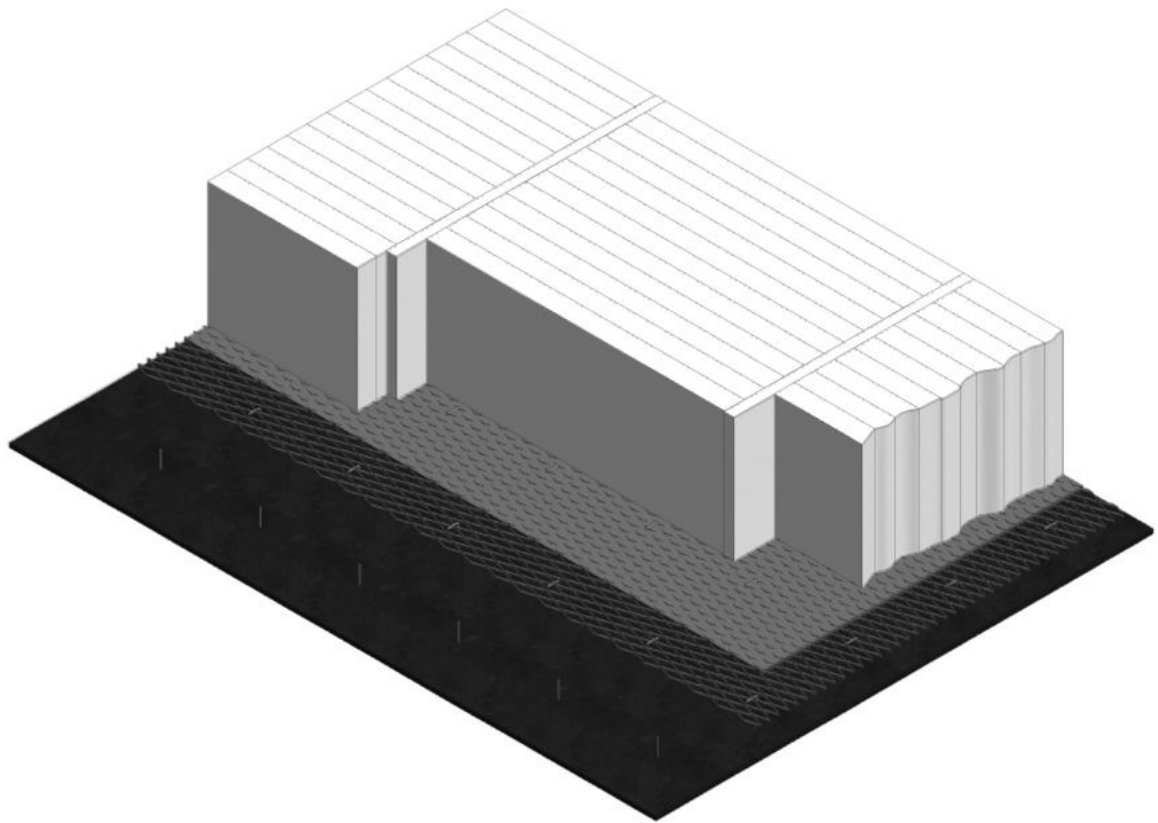

Einbaubeispiel



Ankerkloben

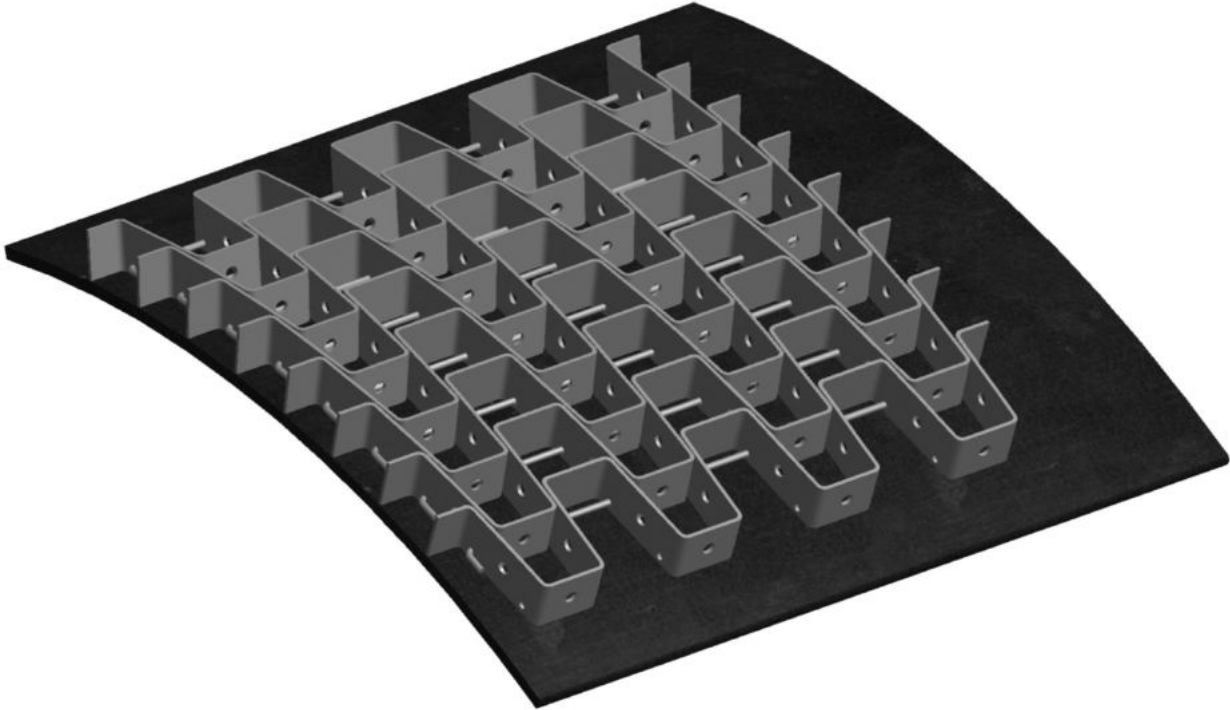

Flexmesh gebogen

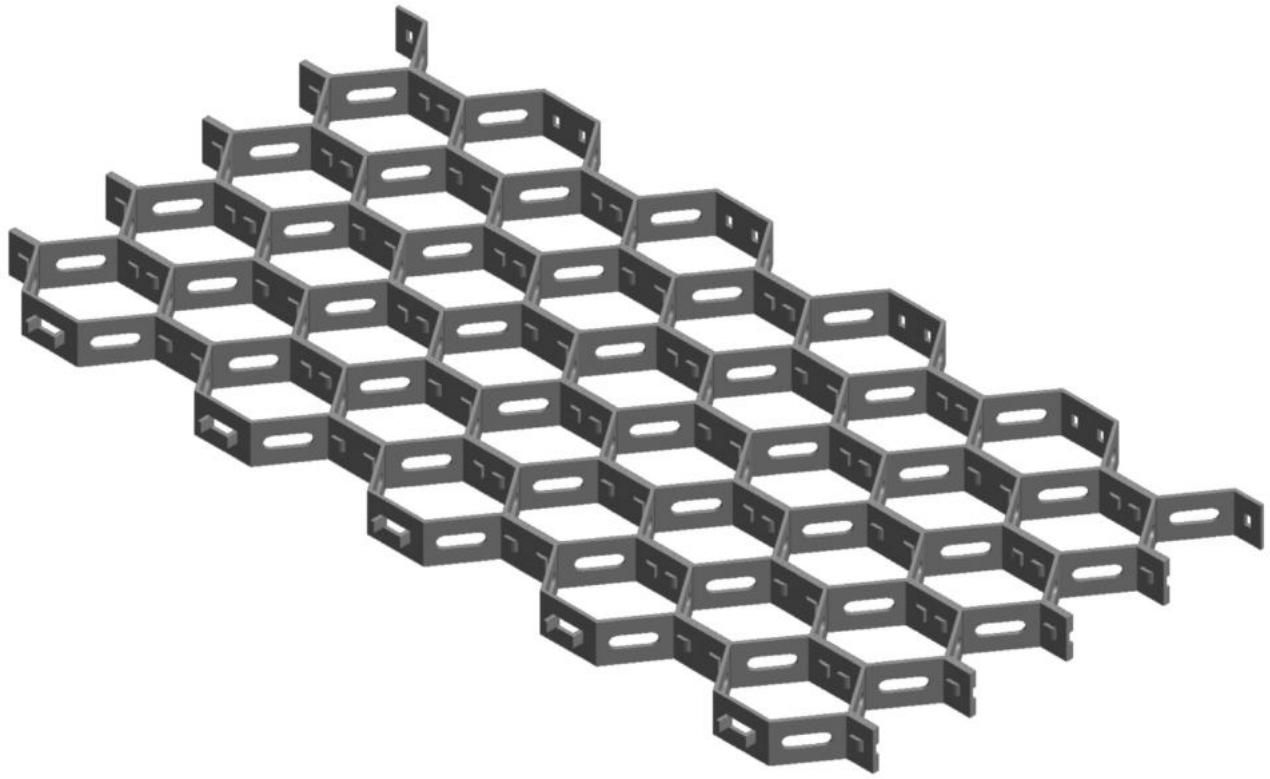

Hexmesh

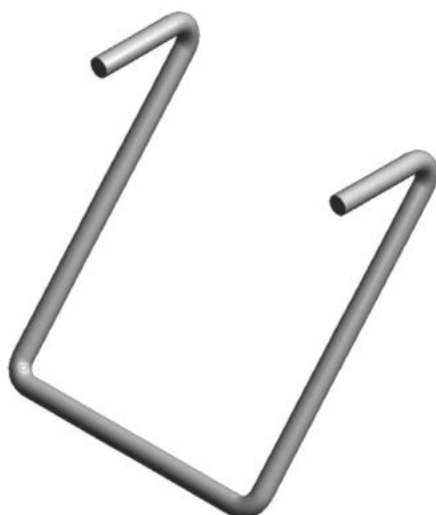

Halteklammer

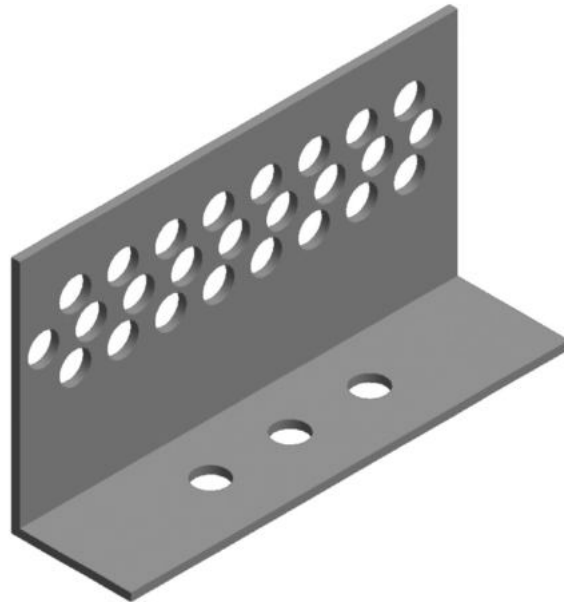

Lochblech

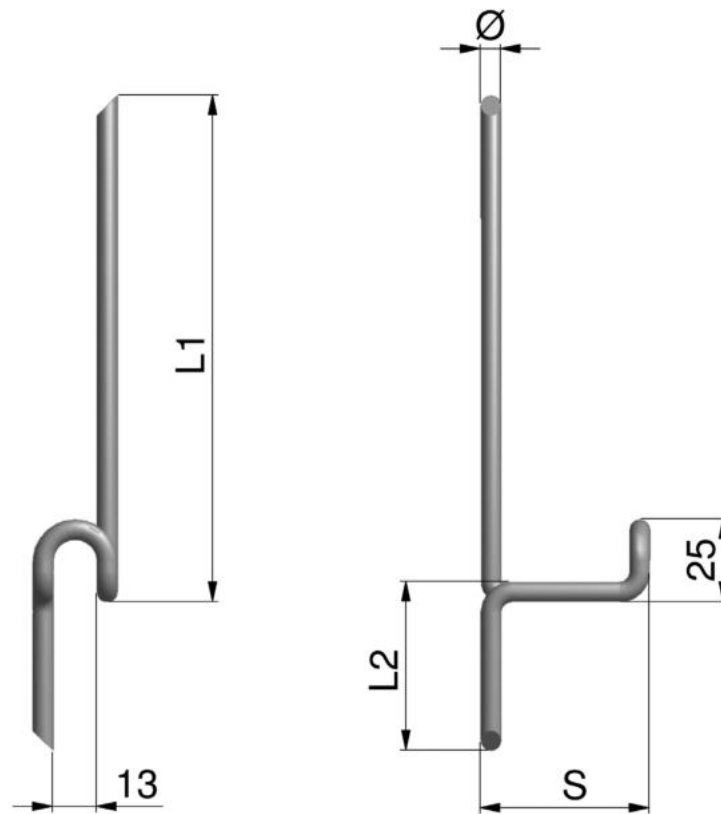

LTB-6-150-50-50-1.4828

Ankertyp
Durchmesser \varnothing
Länge L1
Länge L2
Stemmbreite S
Materialbeispiel

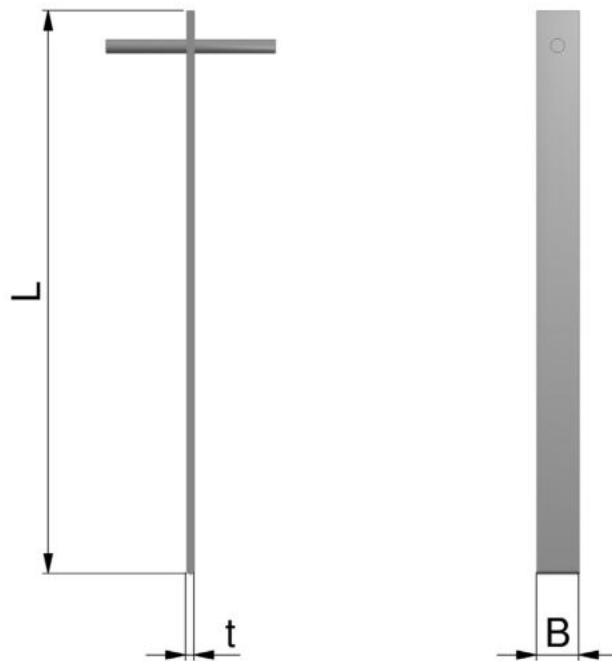

Maueranker-300-40-4-1.4828

Ankertyp

Länge L

Ankerbreite b

Ankerstärke t

Materialbeispiel

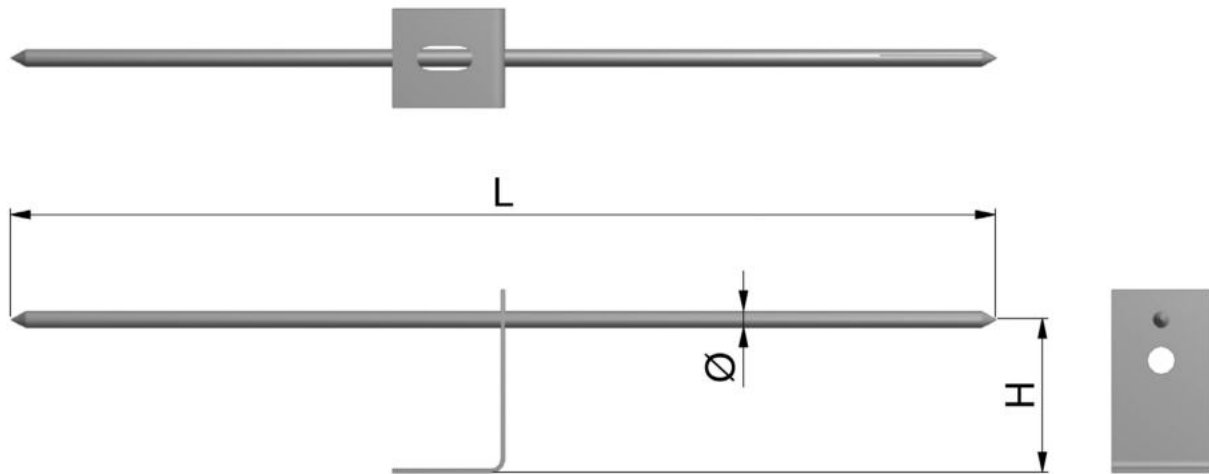

MPU Typ A-350-6-55-1.4828

Ankertyp

Stiftlänge L

Stiftdurchmesser Ø

Höhe H

Materialbeispiel

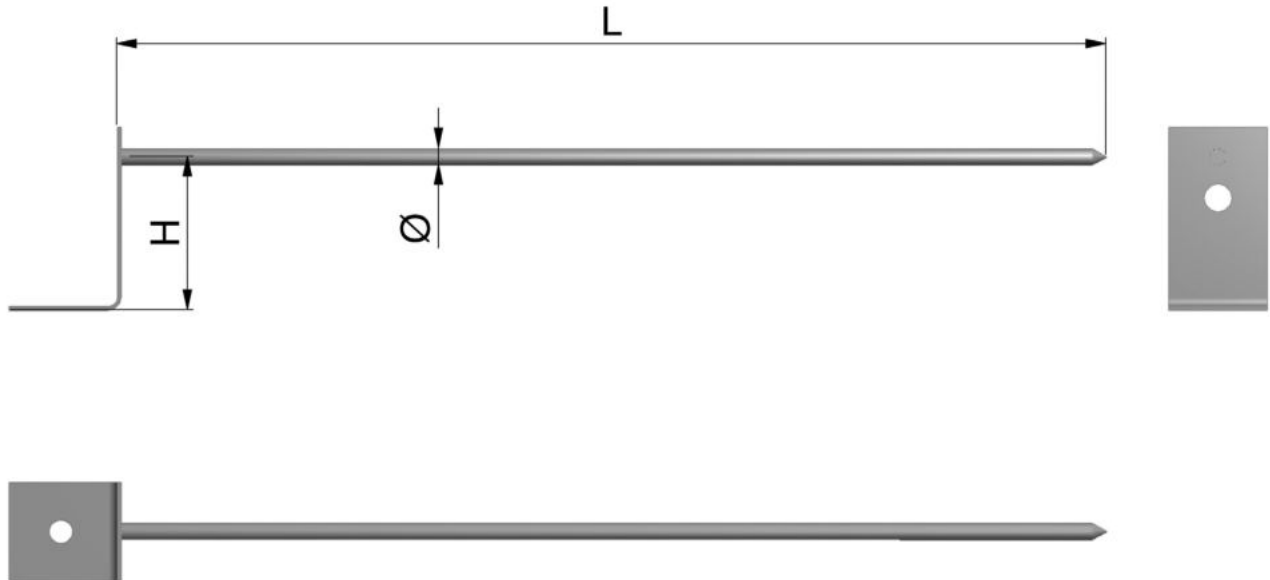

MPU Typ B-350-6-55-1.4828

Ankertyp

Stiftlänge L

Stiftdurchmesser Ø

Höhe H

Materialbeispiel

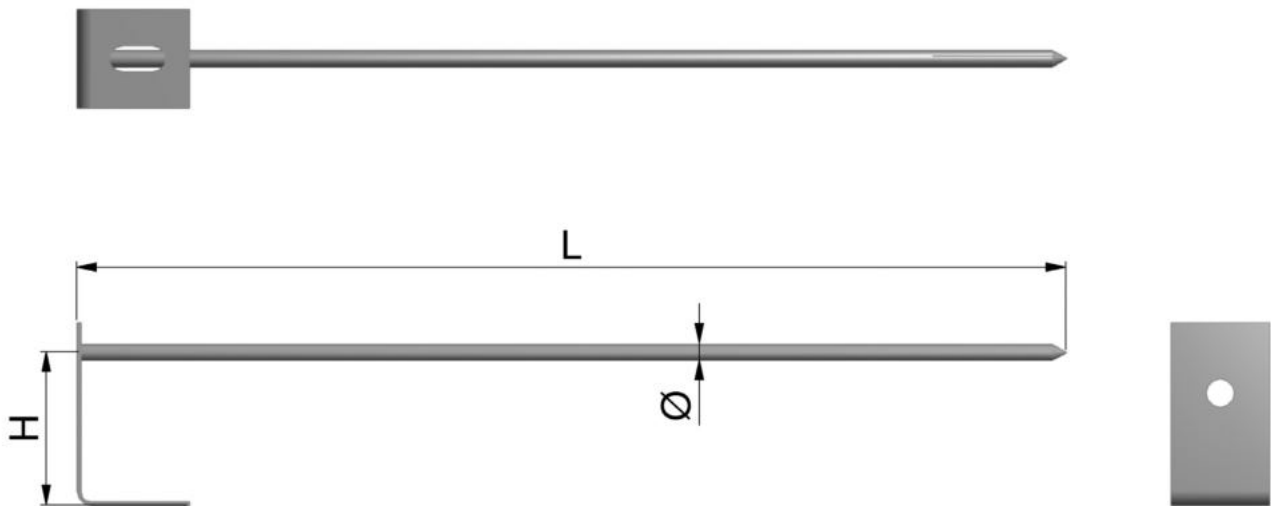

MPU Typ C-350-6-55-1.4828

Ankertyp

Stiftlänge L

Stiftdurchmesser Ø

Höhe H

Materialbeispiel

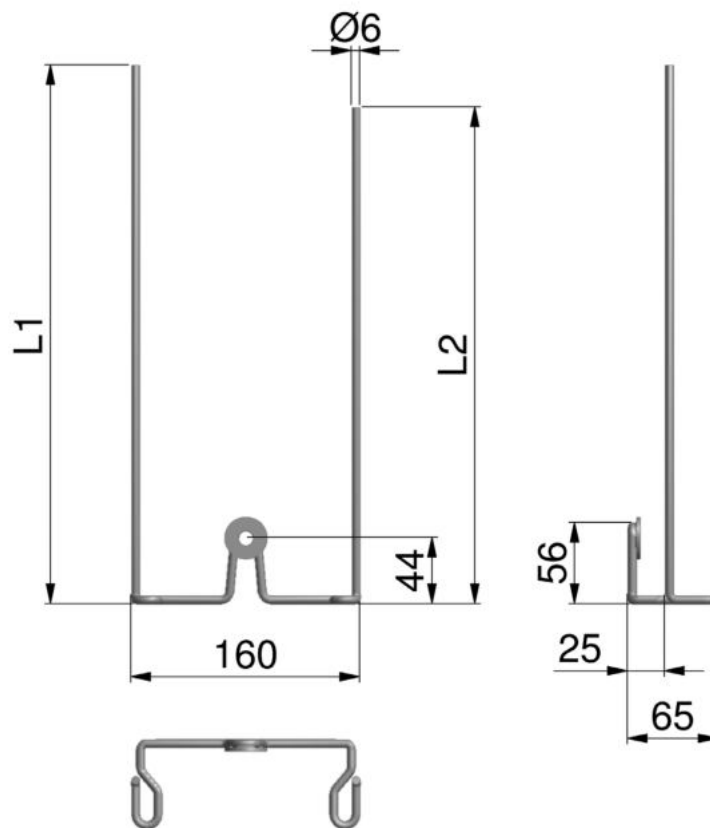

STA-6-380-350

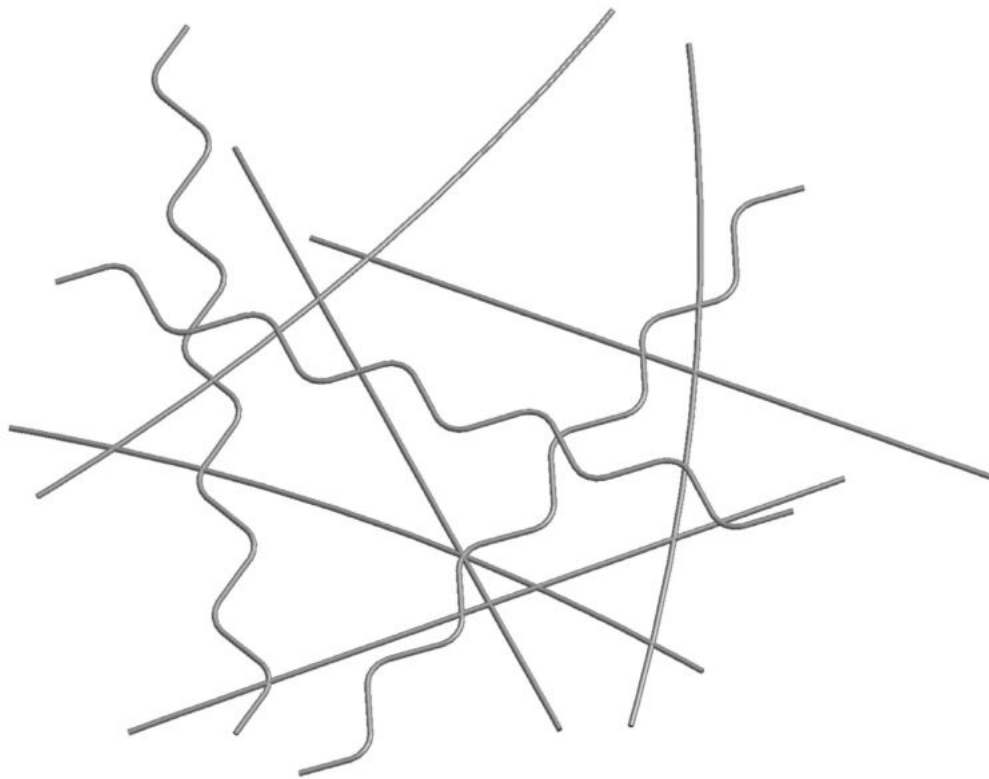

Stahlnadeln

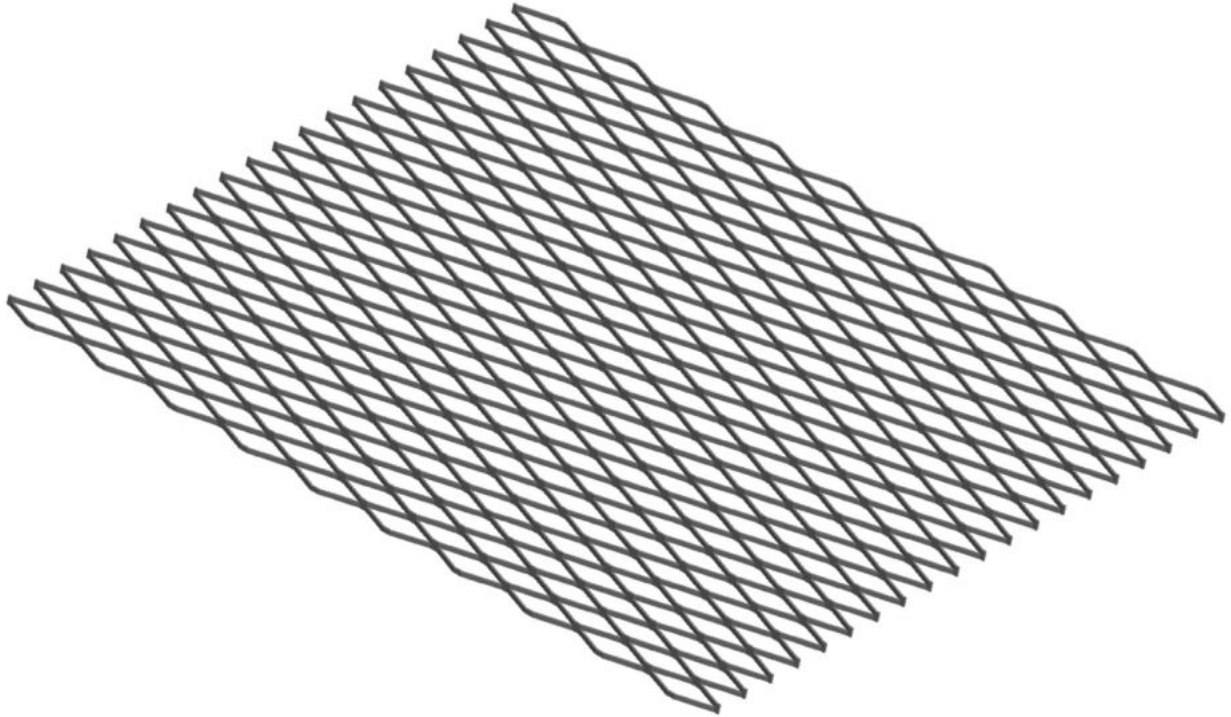

Streckmetall

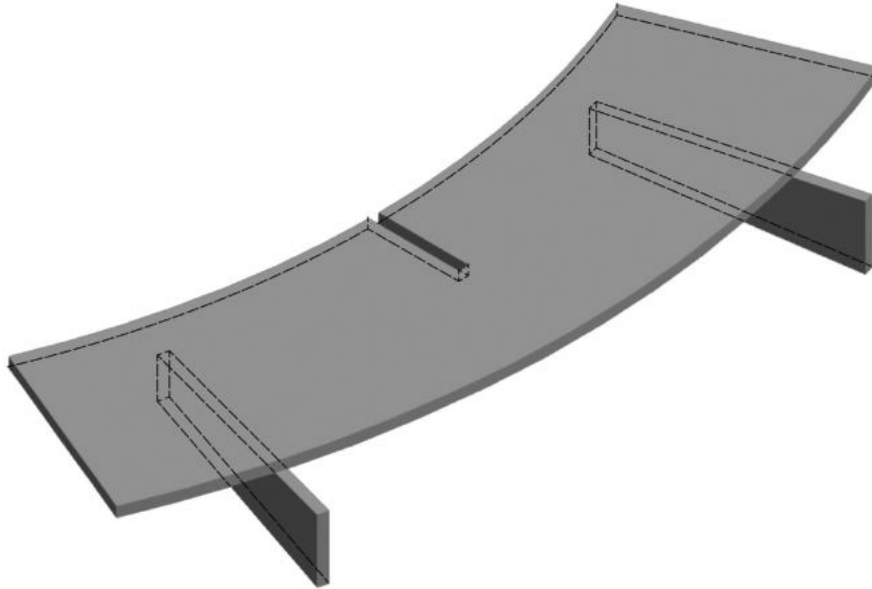

Konsole Type 1

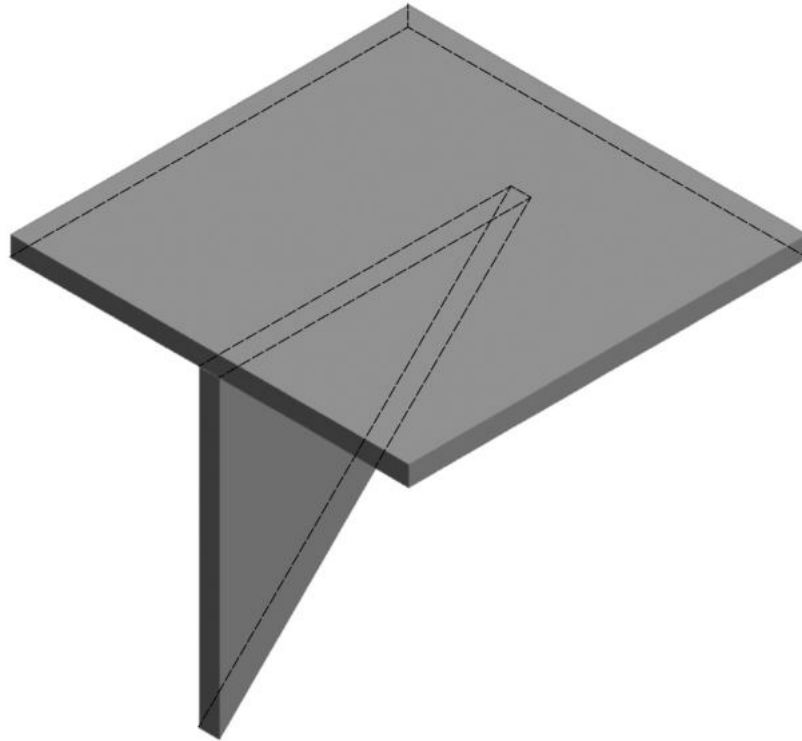

Konsole Type 2

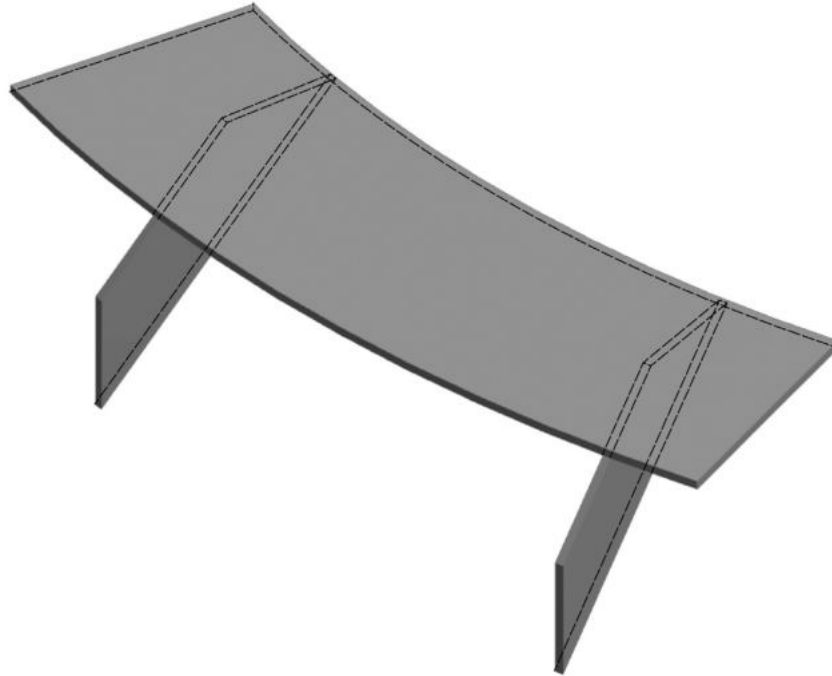

Konsole Type 3

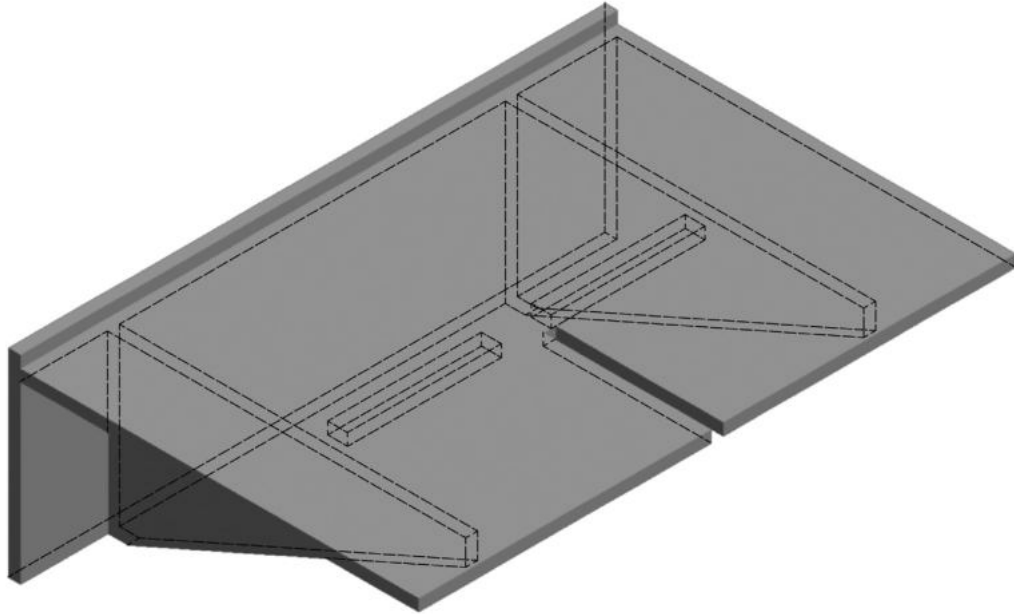

Konsole Type 4

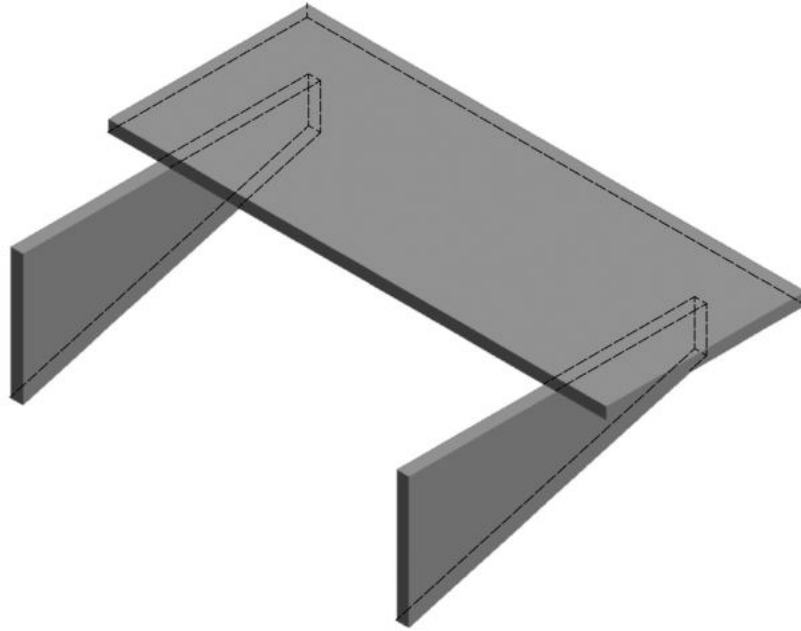

Konsole Type 5

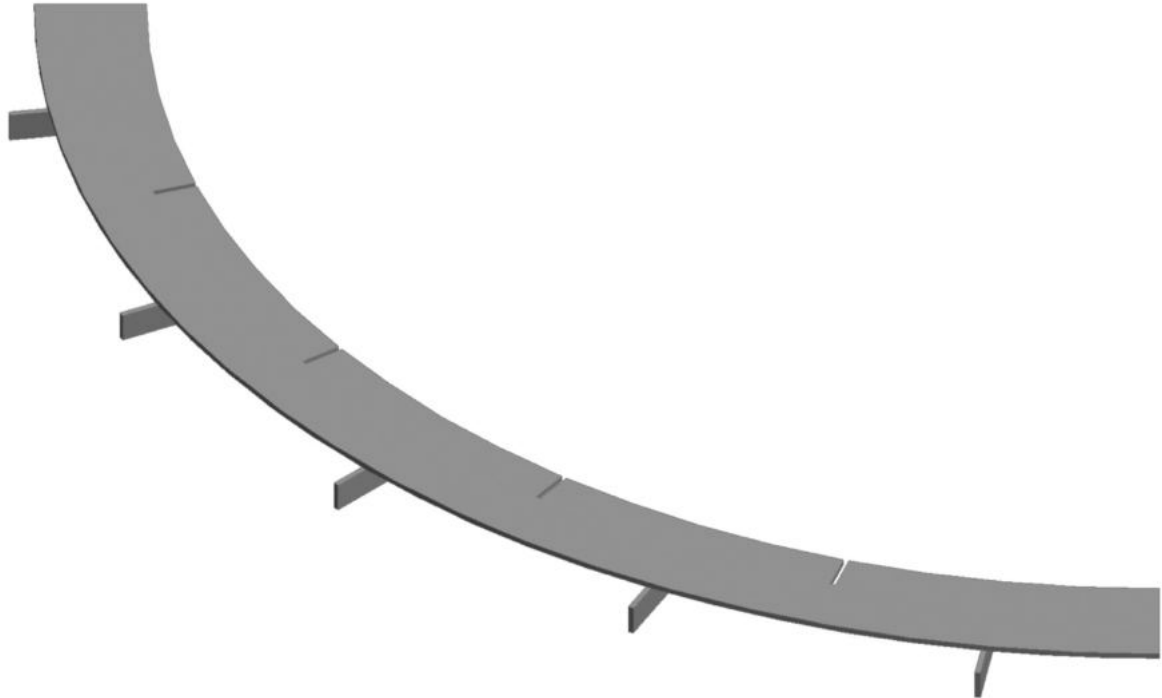

Konsole Type 6