



















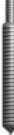

AS Schöler GmbH

Product overview 05

 DRH	 DRP	 DRS	 DRT
 FFH	 FFS	 FFT	 FFD
 IPH	 IPS	 IPT	 TPH
 TPS	 TPT	 DRS-MS	 DRS-M6
 MD	 PD	 RD	 UDB

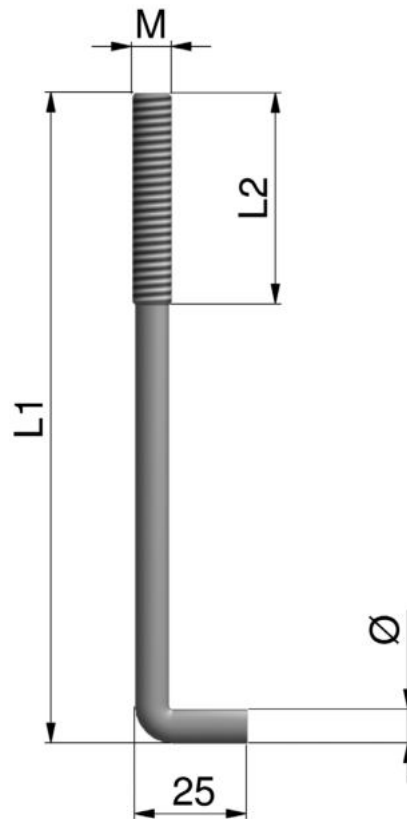

DRH-M6-250-50-1.4841

Stud type

Thread diameter M

Stud length L1

Thread length L2

Alloy type

07 Threaded washer/ Clip/ Square nuts

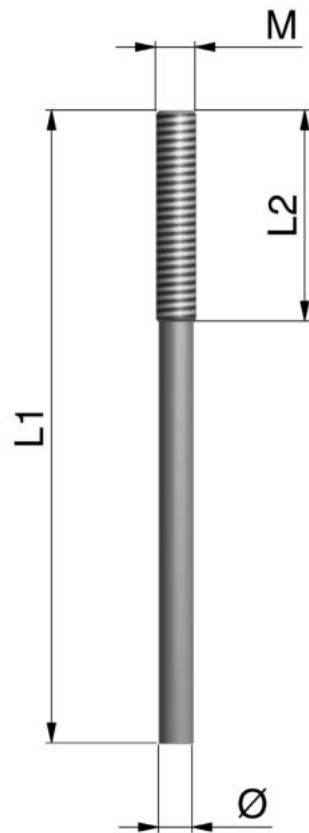

DRP-M6-250-50-1.4841

Stud type

Thread diameter M

Stud length L1

Thread length L2

Alloy type

07 Threaded washer/ Clip/ Square nuts

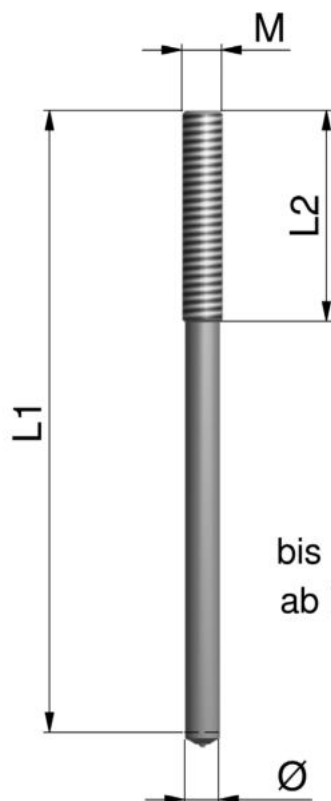

bis M6 ohne Aluminiumkugel
ab M8 mit Aluminiumkugel

DRS-M6-250-50-1.4841

Stud type
Thread diameter M
Stud length L1
Thread length L2
Alloy type

07 Threaded washer/ Clip/ Square nuts

09 Ferrules

10 Stud welding unit/ Welding gun

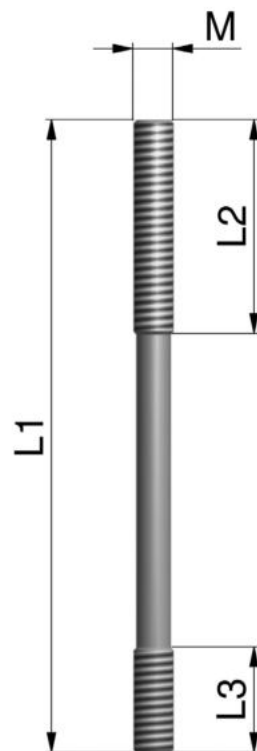

DRT-M6-250-50-25-1.4841

Stud type
Thread diameter M
Stud length L1
Thread length L2
Thread length L3
Alloy type

07 Threaded washer/ Clip/ Tapped stud/ Square nuts

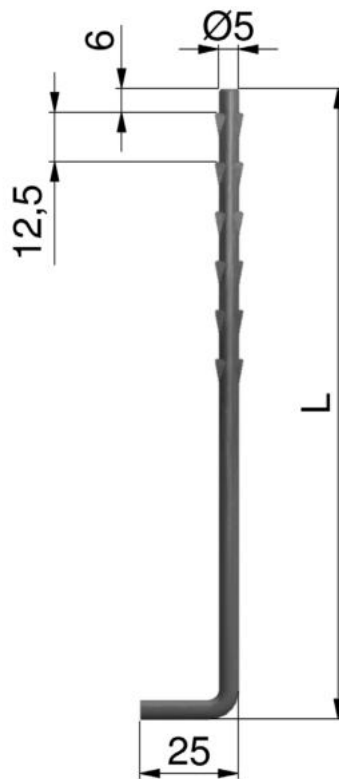

FFH-150-1.4841

Stud type

Stud length L

Alloy type

07 Clip

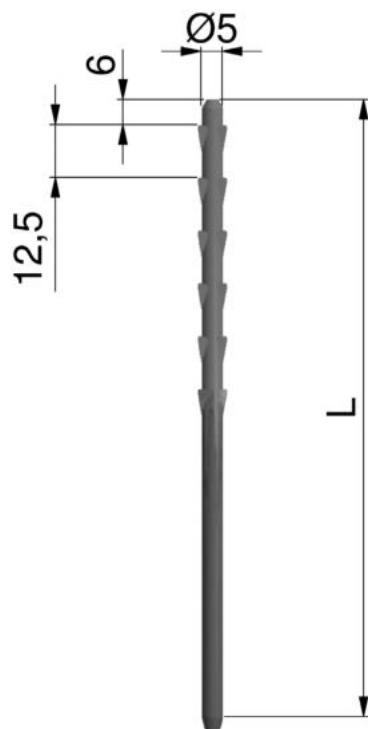

FFS-150-1.4841

Stud type
Stud length L
Alloy type

07 Clip

09 Ferrules

10 Stud welding unit/ Welding gun

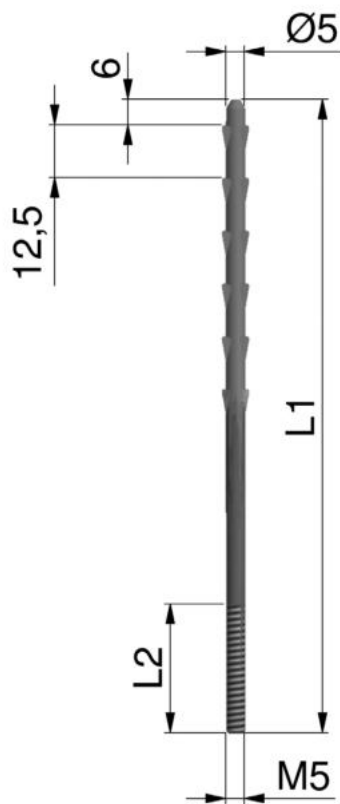

FFT-150-30-M5-1.4841

Stud type
Stud length L1
Thread length L2
Thread diameter M
Alloy type

07 Clip/ Tapped stud

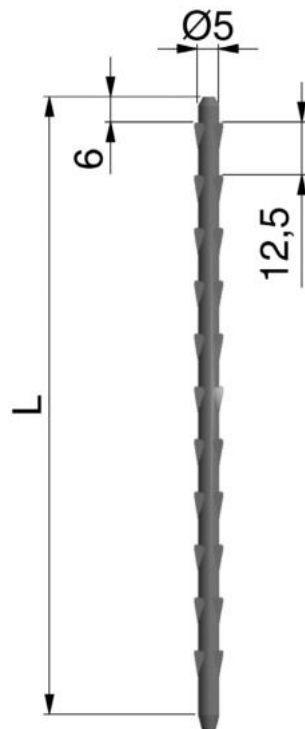

FFD-150-1.4841

Stud type
Stud length L1
Alloy type

07 Clip

09 Ferrules

10 Stud welding unit/ Welding gun

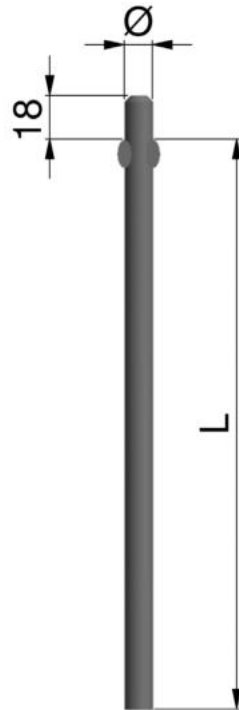

IPH-10-200-1.4841

Stud type

Diameter \varnothing

Stud length L

Alloy type

07 Washer

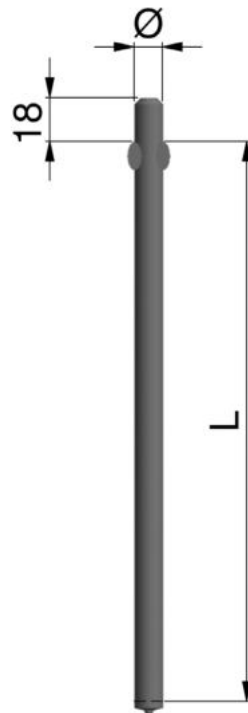

IPS-10-200-1.4841

Stud type
Diameter Ø
Stud length L
Alloy type

07 Washer

09 Ferrules

10 Stud welding unit/ Welding gun



IPT-10-200-30-M10-1.4841

Stud type
Diameter Ø
Stud length L1
Thread length L2
Thread diameter M
Alloy type

07 Washer/ Tapped stud

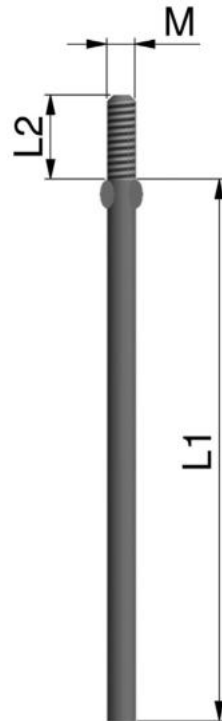

TPH-200-20-M10-1.4841

Stud type
Stud length L1
Thread length L2
Thread diameter M
Alloy type

07 Washer/ Square nuts/ Threaded washer

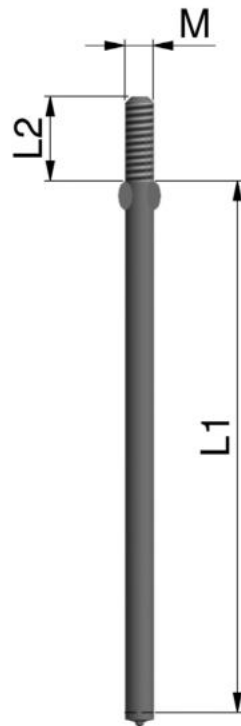

TPS-200-20-M10-1.4841

Stud type
Stud length L1
Thread length L2
Thread diameter M
Alloy type

07 Washer/ Square nuts/ Threaded washer

09 Ferrules

10 Stud welding unit/ Welding gun

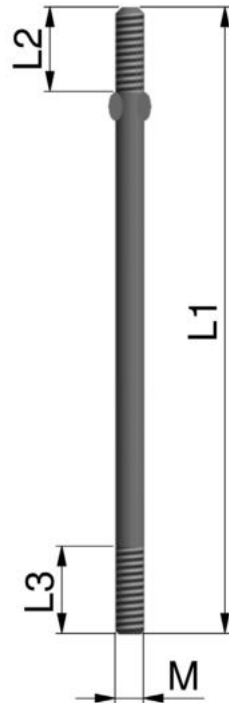

TPT-200-30-20-M10-1.4841

Stud type
Stud length L1
Thread length L2
Thread length L3
Thread diameter M
Alloy type

07 Washer/ Tapped stud/ Square nuts/ Threaded washer

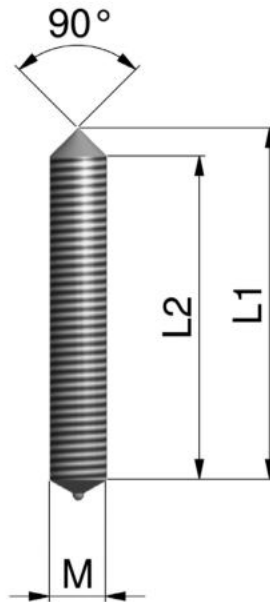

DRS-M8-25-MS-1.4841

Stud type

Thread diameter M

Stud length L1

Alloy type

07 Washer/ Square nuts

09 Ferrules

10 Stud welding unit/ Welding gun

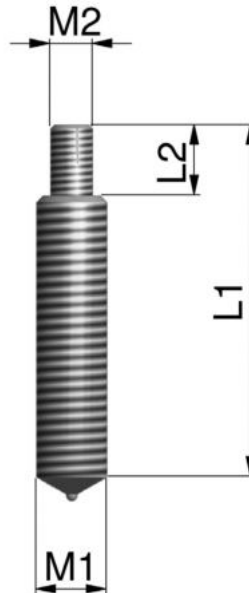

DRS-M10-50-M6-10-1.4841

Stud type
Thread diameter M1
Stud length L1
Thread diameter M2
Thread length L2
Alloy type

07 Washer/ Square nuts

09 Ferrules

10 Stud welding unit/ Welding gun

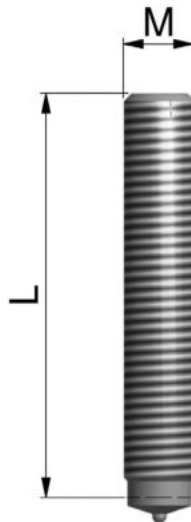

MD-M10-60-1.4301

Stud type

Thread diameter M

Stud length L

Alloy type

07 Washer/ Square nuts

09 Ferrules

10 Stud welding unit/ Welding gun

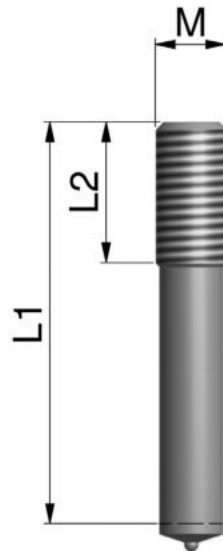

PD-M10-200-20-1.4301

Stud type

Thread diameter M

Stud length L1

Thread length L2

Alloy type

07 Washer/ Square nuts

09 Ferrules

10 Stud welding unit/ Welding gun

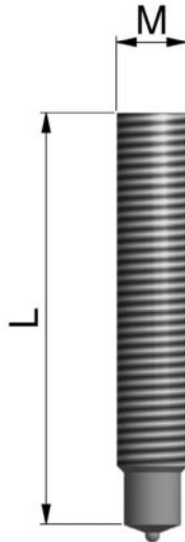

RD-M10-30-1.4301

Stud type

Thread diameter M

Stud length L

Alloy type

07 Washer/ Square nuts

09 Ferrules

10 Stud welding unit/ Welding gun

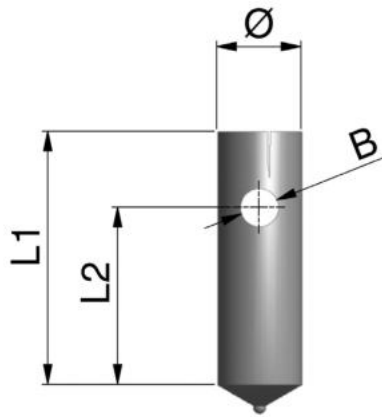

UDB-10-30-20-4,5-1.4841

Stud type

Stud diameter Ø

Stud length L1

Length L2

Drilled hole B

Alloy type

09 Ferrules

10 Stud welding unit/ Welding gun