

<p>CR</p>	<p>KS</p>
<p>SF</p>	<p>SFG</p>
<p>SYP</p>	<p>SYS</p>
<p>SYT</p>	<p>SWP</p>
<p>WS</p>	

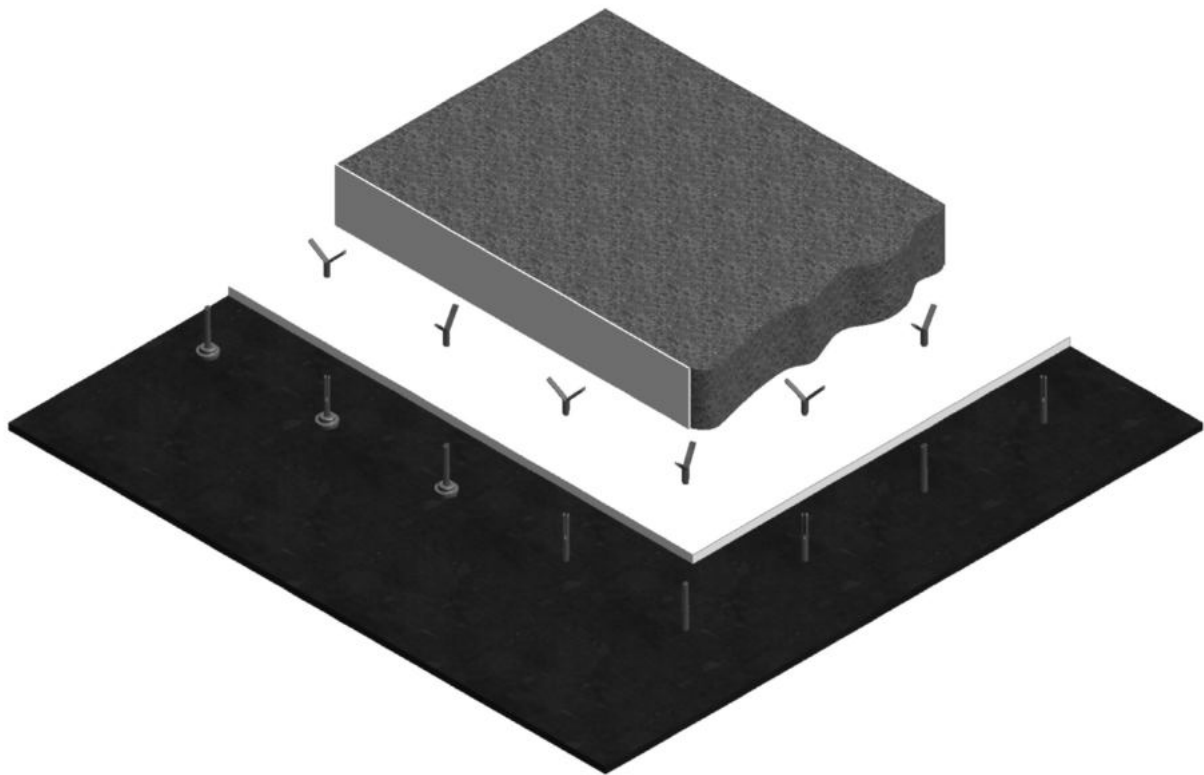

Sample of installation: Product category 3

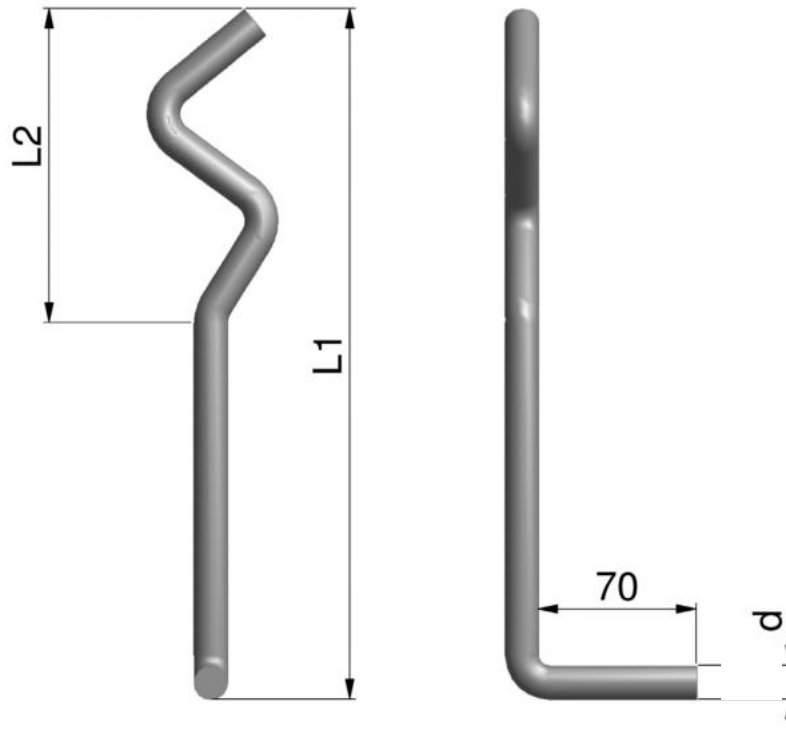

CR-8-250-100-1.4841

Stud type
Diameter d
Stud height L1
Length L2
Alloy type

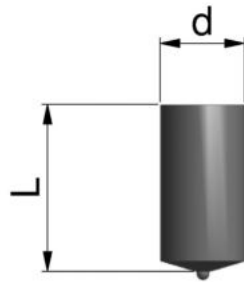

KS-10-20-1.4841

Stud type
Diameter d
Stud length L
Alloy type

09 Ferrules

10 Stud welding unit/ Welding gun

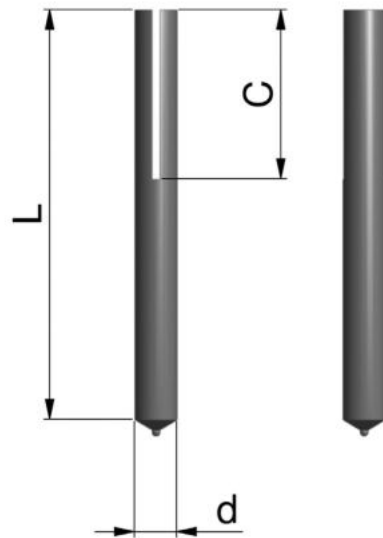

SF-10-100-40-1.4841

Stud type
Stud diameter d
Stud length L
Slot length C
Alloy type

09 Ferrules

10 Stud welding unit/ Welding gun

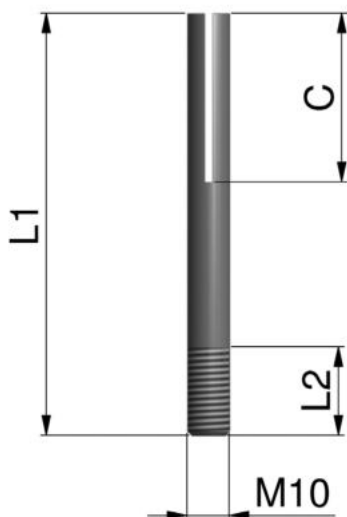

SFG-M10-100-30-40-1.4841

Stud type
Thread diameter M
Stud length L1
Thread length L2
Slot length C
Alloy type

07 Tapped stud



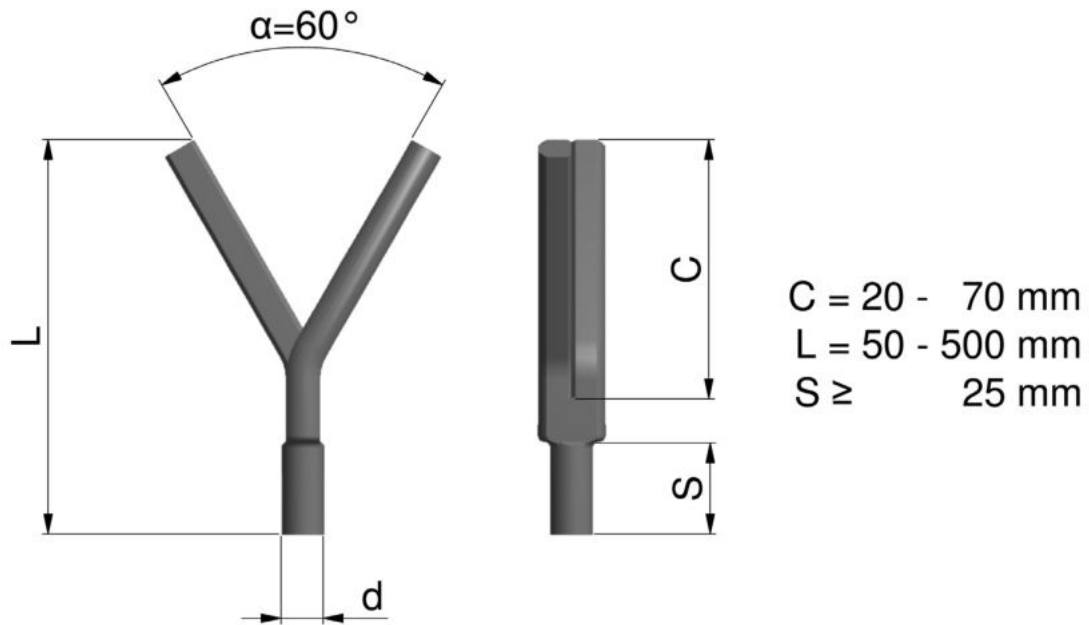

SYP-10-100-50-1.4841

Stud type

Shaft diameter d

Stud length L

Slot length C

Alloy type

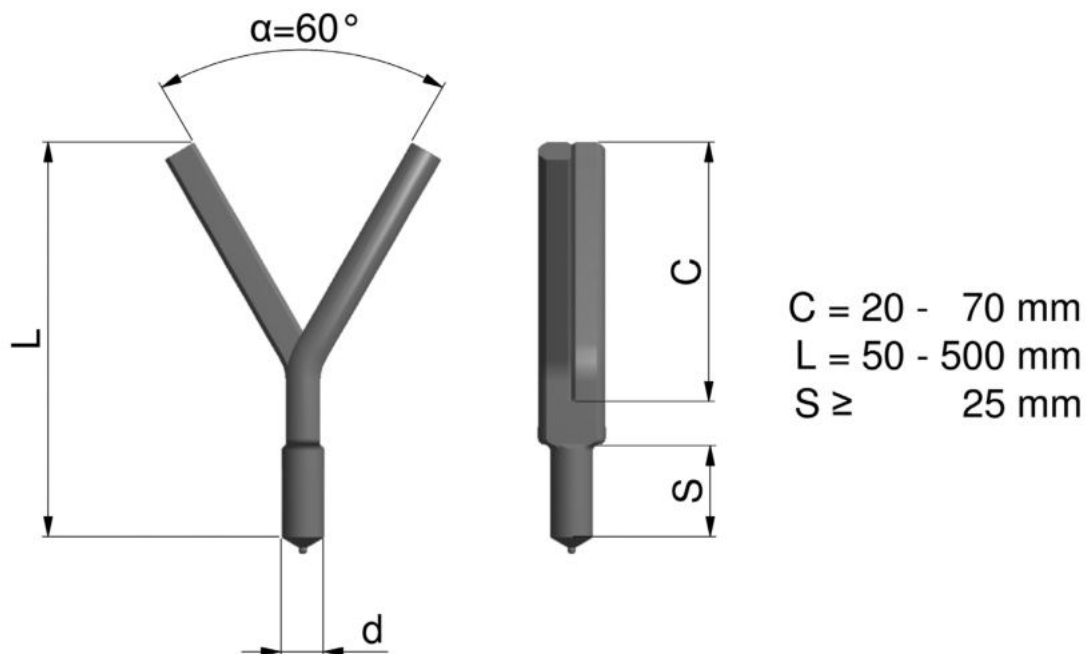

SYS-10-100-50-1.4841

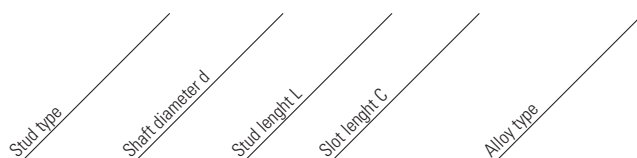

09 Ferrules

10 Stud welding unit/ Welding gun

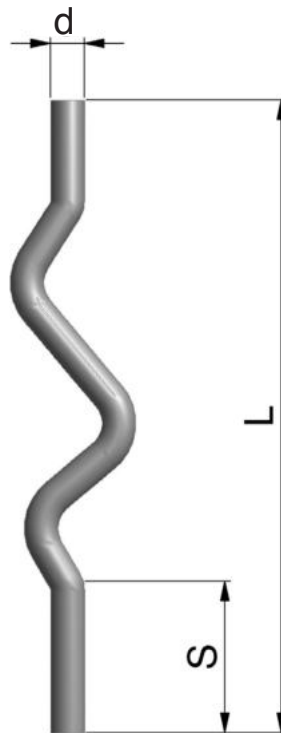

SWP-8-150-35-1.4841

Stud type
Shaft diameter d
Stud length L
Step S
Alloy type



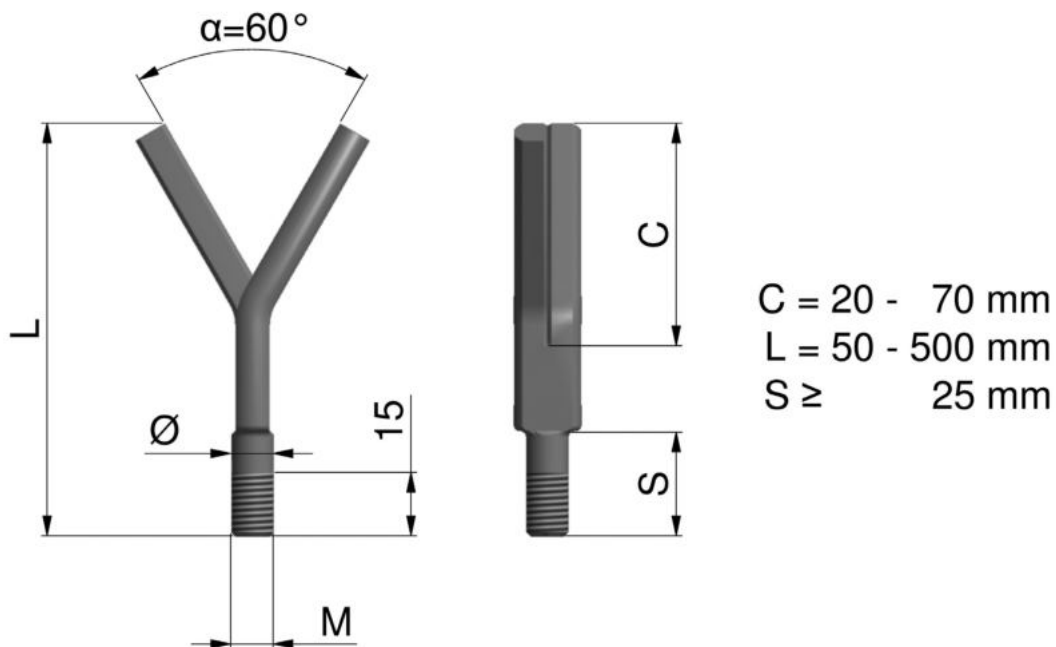

SYT-10-100-50-1.4841

Stud type

Thread diameter M

Stud length L

Slot length C

Alloy type

07 Tapped stud

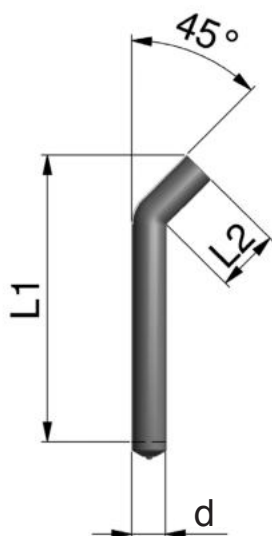

Ø6 ohne Aluminiumkugel
Ø8 mit Aluminiumkugel

WS-6-70-25-1.4841

Stud type

Diameter d

Stud length L1

Length L2

Alloy type

09 Ferrules

10 Stud welding unit/ Welding gun